

Ceiling unit
Pure'line COMPACT 90 cm
Stainless steel

EAN 5414425152735



Energy label

▪ Energy Efficiency class (EEI)	B
▪ Annual Energy Consumption (kWh/year) (AEC _{hood})	62,7
▪ Fluid Dynamic Efficiency class (FDE _{hood})	B
▪ Lighting Efficiency class (LE _{hood})	A
▪ Grease Filtering Efficiency class (GFE _{hood})	D

Functions & features

▪ Control method	Push buttons + Remote control
▪ Number of speeds	3 + power
▪ Automatic Power revert (minutes)	6
▪ Motor	Integrated
▪ Sound absorber	Integrated
▪ Recirculation	Optional
▪ InTouch function	Standard
▪ Auto stop	▪
▪ Delayed switch off (minutes)	10
▪ Number of grease filters	2
▪ Grease filter	6830020
▪ Grease filter cleaning indication	▪
▪ Recirculation filter cleaning indication	▪

Dimensions

▪ Product dimensions (WxDxH) (mm)	868 x 508 x 195
▪ Width flange (mm)	15
▪ Dimensions cut-out opening (WxD) (mm)	845 x 485
▪ Advised mounting height ceramic hobs (H _{min} -H _{max}) (mm)	600 - 1600
▪ Advised mounting height gas and induction hobs (H _{min} -H _{max}) (mm)	650 - 1600
▪ Diameter outlet (mm)	222x89
▪ Position exhaust	Right, Left, Front, Back

Lighting

▪ Functional lighting type	Led
▪ Dimmable light	▪
▪ Soft-ON/OFF	▪
▪ Total energy consumption functional light (W)	8
▪ Color functional light	2700/4000

Airflow and noise level

▪ Airflow (m ³ /h) measured according to EN 61591	
▪ Sound regulation according to DIN 45635-2	
▪ Airflow speed 1 (m ³ /h)	244
▪ Airflow speed 2 (m ³ /h)	443

Airflow and noise level

▪ Airflow speed 3 (m ³ /h)	581
▪ Airflow Powerspeed (m ³ /h)	650
▪ Sound power speed 1 (dB(A)) / Sound pressure speed 1 (dB(A))	41 / 29
▪ Sound power speed 2 (dB(A)) / Sound pressure speed 2 (dB(A))	55 / 43
▪ Sound power speed 3 (dB(A)) / Sound pressure speed 3 (dB(A))	61 / 49
▪ Sound Powerspeed (dB(A)) / Sound pressure Powerspeed (dB(A))	64 / 53

Technical specifications

▪ Maximum power	171
▪ Voltage (V)	220-230
▪ Frequency (Hz)	50-60
▪ Power consumption in stand-by-mode (W)	0,17
▪ Net weight (kg)	27,8

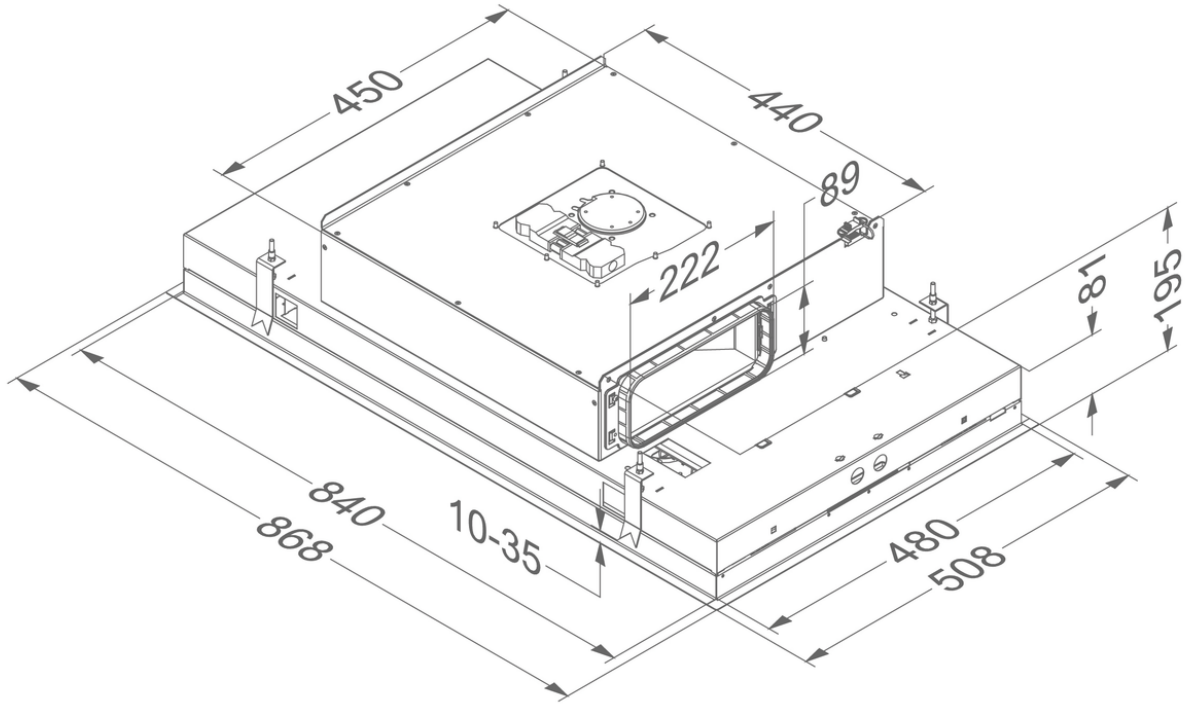

Accessories

Recirculation box

830400

Recirculation box inox with monoblock filter



831400

Recirculation box white with monoblock filter



7900400

Recirculation box inox with monoblock filter 14 cm

Control kit

990030

Control kit for external lighting or valve

